

Barrier-Accessories MAGSTOP

Grille for barrier boom

Barrier boom

The Magnetic aluminium grille is available for all barrier types. It ensures that the area under the boom, when in the horizontal position, is also secured. When the barrier is opened, the grille folds together so that the full width continues to be available for traffic moving through.

The ground clearance of the grille (dimension A) is 41 mm for barriers MSV, and 32 mm for the MTS barriers. In the standard version, the grille element spacing is 115 mm. Narrower spacing is also available on request (e. g. for animals, 40 mm).

A pendulum support or a support post is needed when using booms with the grille attached.

In the case of MTS barriers, the grille can be used without a counterweight, when the boom is 8.0 m or less in length.

Larger booms with the grille are available on request.

spare parts

order number:

| | |
|-----------------------|-----------|
| grille complete MSV | 1043,0212 |
| grille complete MTS | 1043,0213 |
| grille part A MSV | 1043,0287 |
| grille part A MTS | 1043,0288 |
| grille part B MSV/MTS | 1043,0215 |
| grille part B MSV/MTS | 1043,0289 |

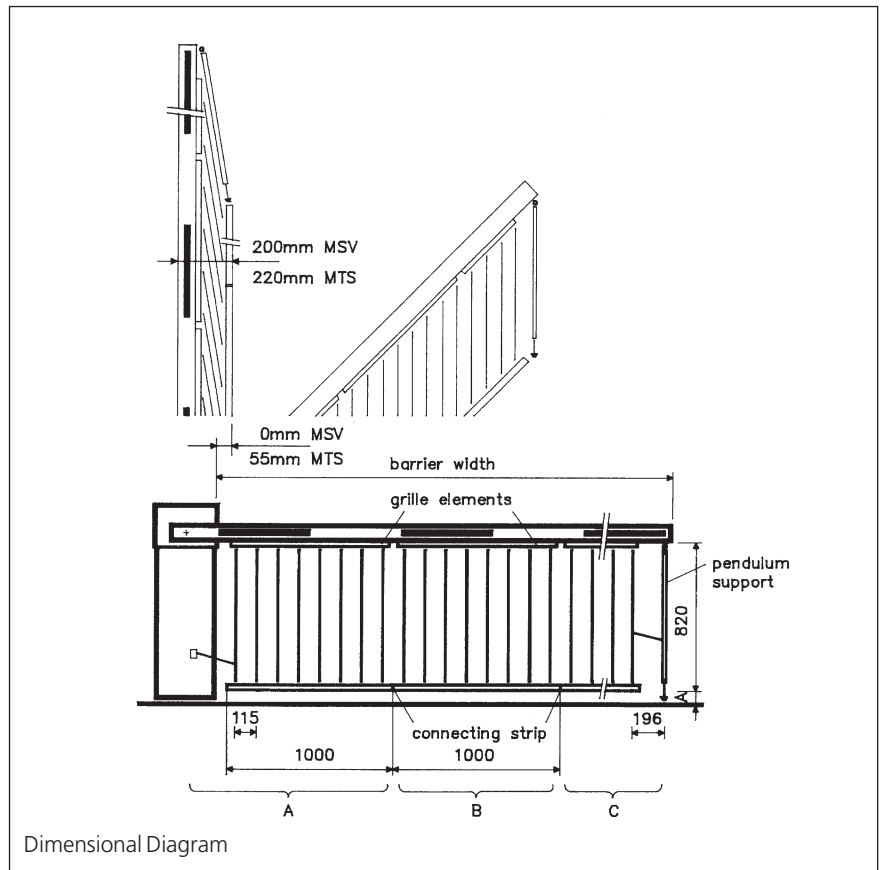

Assembly:

After the boom has been assembled, the individual preassembled grille elements must firstly be bolted onto the boom. Then the grille elements must be linked together at the lower aluminium angle section. This ensures that all elements fold simultaneously during opening.

A space is provided at the front end of the boom to fit the pendulum support. Assembly and adjustment of the pendulum support should be carried out in accordance with Info MF 5141.

