



catrax

master

Catrax Master was manufactured in a smaller size, with lightweight materials, saving space and enhancing resistance. Its innovative design combined with the optional finish offer a broad variety of configurations. This allows customizing and adjusting the product to meet specific needs.



SPECIAL DESIGN



The top panel is manufactured in high impact engineering plastic, is available with a stainless steel finish, and can be customized with the customer's own brand identity. In addition, it is safer for the user, since it has rounded corners and there are no exposed screws.

ACCESS PERMISSION



The pictograms on the side and at the top inform access permission and detect direction of movement.

SYMMETRY



The two columns at the ends provide more room for system's integration. This model is manufactured with a U-shaped mounting drawer that can be easily removed or replaced for the assembly and maintenance of electronic components. Access is gained by a key lock.



CUSTOMIZED FINISH

The pedestal can be manufactured in acrylic, polycarbonate, brushed stainless steel and temperate glass.

RELIABILITY AND SAFETY

Optical sensors and electromagnets are used to activate locks, thus preventing mechanical wear and increasing equipment life.

SMOOTHER PASSAGE

Arms with a 90-degree passageway allow for a smooth turn and lessen the impact of the turnstile arm on patrons after each passage.



TECHNICAL CHARACTERISTICS

- Locking mechanism activated by electromagnets instead of solenoids, giving greater reliability;
- Rotation signals generated by high output optical sensors, completely avoiding mechanical wear;
- The cabinet is composed of an internal monoblock structure made of welded steel parts coated with epoxy powder coating. The external cabinet is made of carbon steel plates with high-resistance powder epoxy coating;
- **Optionally**, the cabinet can be made of brushed stainless steel (AIS 304). Arms are manufactured in polished stainless steel;
- The top cover consists of a stainless steel plate, finished with high impact injection-molded plastic parts, offering strength and rounded corners, along with excellent appearance;
- No visible screws: access to the internal components of the turnstile is by lock and key;
- Two automotive grade roller bearings increase equipment life, avoiding unnecessary maintenance;
- High performance mechanism for operation under heavy traffic flow;
- Turnstile rotates freely in case of emergency or power failure;
- Easily adapted and integrated to any terminal/technology. Catrax Master allows for easy installation of proximity or Smart Card readers on the two upper sides of the cover;
- Optional SMD assembled controller board (interface between the turnstile and integrator electronic control), with configurable electromagnet protection system offering 4 inputs and 5 outputs. It allows four turnstile configurations: forward rotation, backward rotation, rotation in both directions and locked in both directions. In addition, the controller board allows time outs and returns signals, informing the passage of a user;
- Optional switching power supply – input between 90 and 250 VAC and output of 12 VDC/2A, with protection against electrical surges;
- Optional pictograms on the frontal part of each leg help users identify the direction of passage. A green arrow indicates in operation passage, and a red "X" indicates out of operation;
- Optional card collection unit can be integrated into the turnstile. The collection box has an infra red card detection device, an electromagnetic device to retain and collect cards, and a container to store up to 200 cards. Access to the container is through locked door key. The unit also contains a window for card reader installation;
- Optional no-break system allows the turnstile to work for a period of up to 4 hours. The no-break charges a battery and has a shut down device in case of emergency.

EASY PROGRAMMING

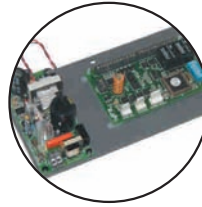

Optional microprocessor controller board allows for total integration with a variety of available solutions access denied.

DIMENSIONS

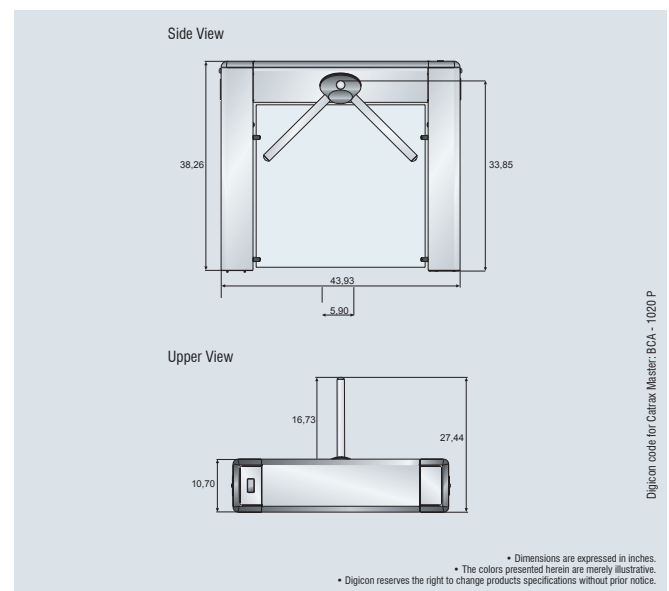

PART NUMBER CONFIGURATION

AAA	BB	C	D	E	F	
						AAA – Catrax Master – Materials
						209 – Stainless Steel Cabinet
						210 – Carbon Steel Cabinet
						BB – Top Panel Plastic – Colors and models
						11 - Black standard
						12 - Green standard
						13 - Bordeaux red standard
						C.D.E.F - Optionals
						4 – If included Microprocessor Controller Board
						5 – If included Power Supply
						6 – If included Pictograms of operation
						7 – If included Pictograms of orientation
						8 – If included Card Collector